

APPLICATION:

PRODUCT NAME:

DrainKing WASTE VALVE
ROUGH CHROME

JOB NAME:

SPECIAL CONFIGURATION
 CHECK BASE MODEL AND OPTIONS

QUANTITY:

ITEM NO.

MODEL:

- 28940 W/ FLAT STRAINER & 19" X 21" OVERFLOW
- 28967 W/ FLAT STRAINER & 14" X 16" OVERFLOW

OPTIONS OR MODIFICATIONS:

OTHER _____

FEATURES

- * DUAL TEFLON SEALS
- * STAINLESS STEEL BALL
- * CAST RED BRASS BODY, CHROME PLATED
- * EXTRA STURDY STAINLESS STEEL CLAMPING RING
- * "CLEAR THROUGH" OPENING - NO NEED TO DISASSEMBLE IF SNAKING IS REQUIRED
- * INDUSTRY STANDARD "SEALING" ANGLE - FITS FLUSH TO STANDARD STAINLESS STEEL SINKS
- * STAINLESS STEEL FLAT STRAINER
- * 1/4 TURN FULLY OPENS AND CLOSES VALVE

DRAIN RATE

- * 12 GPM

SHIPPING WEIGHT

- * 10.0 LBS

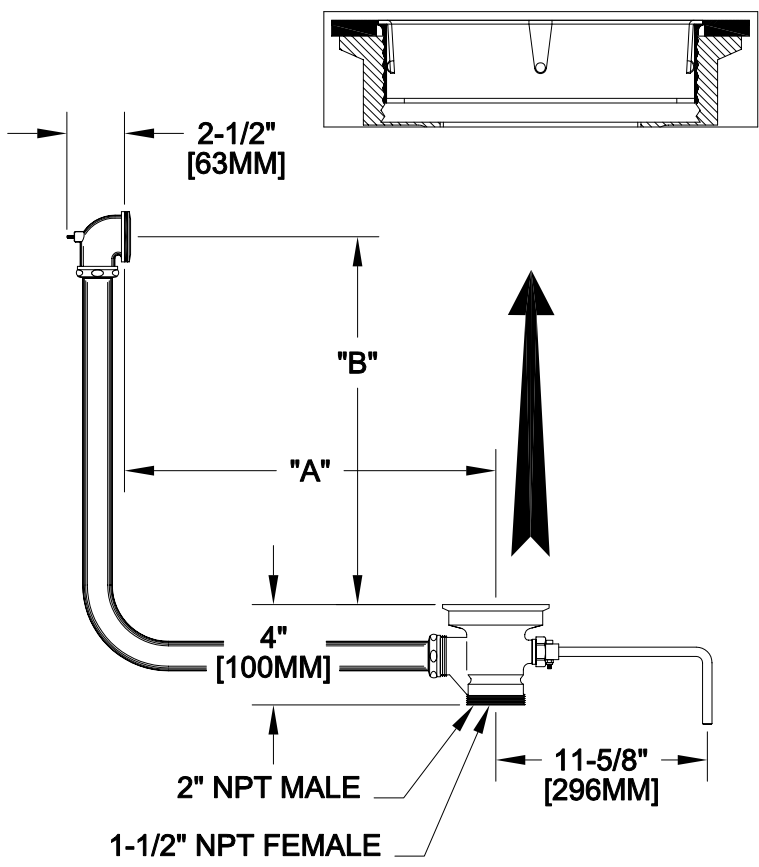

MODEL	DIM "A"	DIM "B"
28940	19" [483MM]	19-1/4" [489MM]
28967	14" [355MM]	14-1/4" [362MM]

ROUGH-IN:

OVERFLOW

DRAIN



Ø1 5/8"
[41MM]

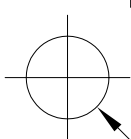

Ø3-1/2"
[88MM]

